

Diagnostix™ 952B



- Wall Mount Instructions
- Schematics
- Parts List
- Maintenance

ADC[®]
AMERICAN DIAGNOSTIC CORPORATION

WALL MOUNTING INSTRUCTIONS (1 OF 2)

Tools Needed

- Medium slotted screwdriver
- Hammer
- Drill with 3/16" drill bit

Wall Mount Instructions

1. Unit may be wall mounted without disassembling main unit from swivel base/wall mount bracket. Position bracket so that center of unit is approximately 4'6" from the floor. Using a pencil, mark the holes on either side of the wall bracket.
2. Check for level and drill 3/16" holes approximately 7/8" deep. Gently tap the 2 screw anchors into the holes until they are flush with the wall.
3. Position the manometer and bracket and mount to the wall using supplied screws. Take care not to overtighten screws. Position the cuff basket approximately 2" to the right of the manometer.
4. Using a pencil, mark the 3 holes as before. Repeat the procedure for drilling the holes, inserting anchors, and mounting.
5. Attach 8 foot length of coiled tubing to air inlet underneath mounting bracket. Insert "male" luer connector on free end of coiled tubing to "female" luer connector on bladder tubing. Wrap cuff around bulb and store in the basket.

Important: This instrument is designed to permit wall mounting without first disassembling main unit from its swivel base/mounting bracket.

To remove main unit from bracket, disconnect tubing from mounting bracket. Unscrew wingnut from bottom of mounting bracket, separating main unit from bracket. Reverse procedure to reassemble.

WALL MOUNTING INSTRUCTIONS (2 OF 2)



CONNECTING THE INFLATION SYSTEM TO MANOMETER

Remove red safety cap which seals the reservoir containing mercury (on the 952, the red safety cap is located on the air inlet beneath swivel base). Attach free end of reservoir tube securely to air inlet. Save red safety cap for later use. When transporting mercury instrument we recommend placing the red safety cap on reservoir.

Please Note: It is normal for negligible amounts of residual mercury droplets to accumulate around the air inlet beneath the red safety cap during transportation.

MAINTENANCE

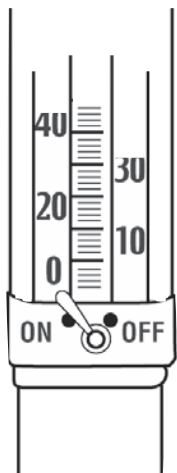

To Lock Mercury Within the Reservoir: Tilt the entire unit back 45° towards the reservoir to permit mercury to flow out of cartridge tube and into reservoir. When cartridge tube is completely emptied of ALL mercury (and while it is still tilted 45°), move locking lever to the right "OFF". Mercury should be locked within the reservoir during maintenance or transport. To release mercury, move lever to "ON" position. If necessary, tilt unit towards tube to allow mercury to flow out of reservoir.

Lift on the spring loaded EZ-Tube™ mechanism located at the top of the instrument. Tilt instrument forward to free tube. If necessary use a small flathead screwdriver to help dislodge the top of the tube. To replace tube, lift EZ-Tube™ mechanism and insert base of tube into main unit, being sure graduation marks face out. Next, position top of tube and release EZ-Tube™ mechanism.

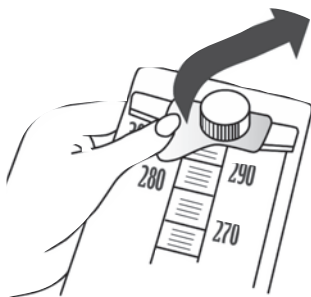

SCHEMATIC PARTS LIST (1 OF 2)

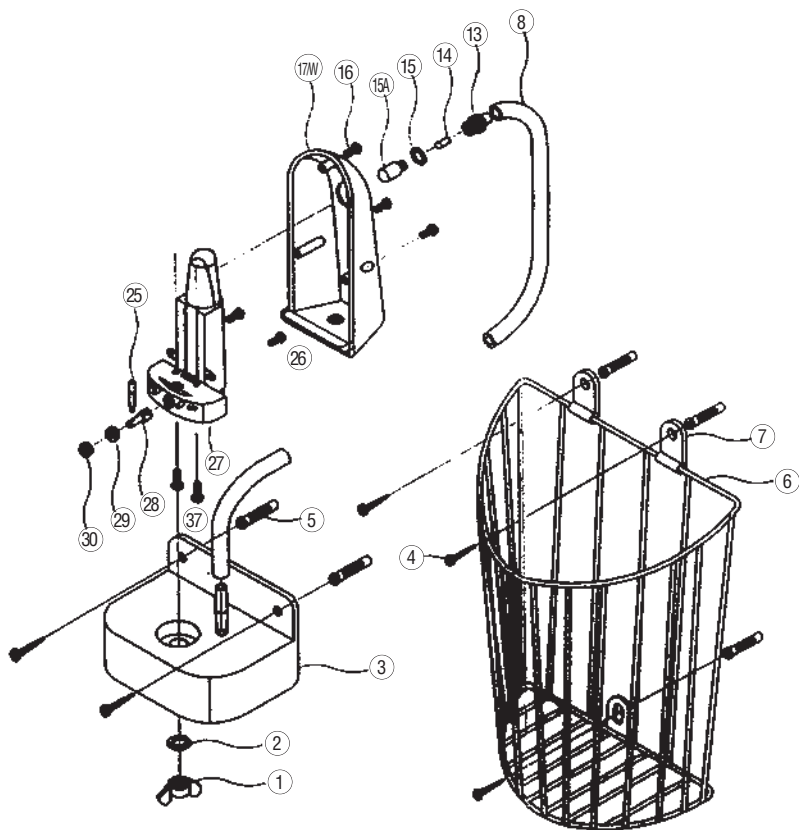

SCHEMATIC PARTS LIST (2 OF 2)

952B UNIT

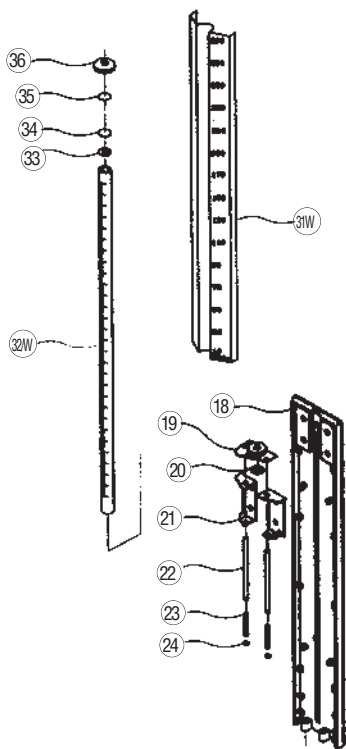

Ref #	Item #	Description
1	952-101	Butterfly Nut
2	952-102	Fitted Washer
3	952-103	Mounting Bracket
4	952-104	Basket Screws (5)
5	952-105	Molleys (5)
6	952-025	Cuff Basket
7	952-107	Basket Clips (2)
8	952-108	Rubber Tube
13	952-109	Reservoir Connector
14	952-110	Cotton Filter
15	952-111	Reservoir Connector Gasket
15A	952-112	Reservoir Feeder Tube
16	952-113	Reservoir Cover Screws (3)
17W	952-114	Reservoir Cover
18	952-115	Scale Plate Holder
19	952-116	Cartridge Top Plate
20	952-117	Rubber Gasket
21	952-118	Reservoir Holder for Top Plate
22	952-119	Rods (2)
23	952-120	Springs (2)
24	952-121	Locking Washers (2)
25	952-122	Locking Lever Handle
26	952-123	Reservoir Screws (2)
27	952-124	Reservoir Tank
28	952-125	Reservoir Rod
29	952-126	Bushing
30	952-127	Locking Screw
31W	952-128	Scale Plate
32W	952-129	Graduated Plastic Cartridge Tube
33	952-130	Rubber Gasket
34	952-132	Filter Plug
35	952-131	Diaphragm
36	952-133	Screw Cap
37	952-134	Reservoir Base Screws (2)

To Register Your Product, visit us at www.adctoday.com and follow the links



ADC
55 Commerce Drive
Hauppauge, NY 11788

tel: 631-273-9600, 1-800-232-2670
fax: 631-273-9659

www.adctoday.com

email: info@adctoday.com



ADC (UK) Ltd.
Unit 6, PO14 1TH
United Kingdom